

# Grid Tied Residential Inverter Installation and Operations Manual

## Models 1100, 2000, 2800, and 3000

---



### Contact Information

*PV Powered, Inc.*

150 Scalehouse Loop #101

Bend, OR 97702

Phone: 541-312-3832

Fax: 541-383-2348

Toll Free: 877-312-3832

Email: [support@pvpowered.com](mailto:support@pvpowered.com)

**PVPowered**

## Table of Contents

IMPORTANT SAFETY INSTRUCTIONS .....	4
1 INTRODUCTION .....	5
2 INSTALLATION .....	5
2.1 Selecting a Location for the Inverter .....	5
2.2 Mounting the Inverter.....	5
2.2.1 Mounting the Inverter .....	6
2.3 Electrical Connections.....	7
2.3.1 Inverter Voltage and Frequency Limits.....	8
2.3.2 Separation of Circuits .....	9
2.3.3 Grounding .....	10
2.3.4 GFI Circuit .....	11
2.3.5 Connecting the Inverter to the Electrical Grid.....	12
3 OPERATION .....	17
3.1 Start-Up Procedures for the Inverter.....	17
3.2 Inverter Front Panel Status Indicators.....	17
3.2.1 LED Indicator Lights.....	17
3.2.2 Vacuum Fluorescent Display (VFD).....	18
4 TROUBLESHOOTING .....	19
4.1 Red and Green LED Lights ON.....	19
4.2 Displayed Fault Codes .....	20
4.2.1 Multiple Faults.....	20
4.2.2 Fault Code List .....	21
5 SPECIFICATIONS.....	23
5.1 Operational Specifications .....	23
5.2 Abnormal Specifications .....	24
6 LIMITED WARRANTY .....	25
6.1 Term of Coverage .....	25
6.2 Coverage.....	25
6.3 What is Not Covered.....	25
6.4 Disclaimer and Limitation of Liability.....	26
6.5 Arbitration .....	26
6.6 Miscellaneous Provisions .....	27

7 RETURN PROCEDURE .....28  
7.1 Information about Your System .....28

## ***IMPORTANT SAFETY INSTRUCTIONS***

This product has been engineered and manufactured to ensure your personal safety. Improper use may result in potential electrical shock or burns. Please read and follow all instructions for installation, use and servicing of this product.

NOTE: A locking tab has been designed into the PV Powered Grid Tied Residential Inverter line. It is the sole responsibility of the end user to provide a locking mechanism that utilizes the tab, and secures the cover on the inverter.

**SAVE THESE INSTRUCTIONS – This manual contains important instructions for the PV Powered Grid Tied Residential Inverter product line that must be followed during installation and maintenance of these inverters.**

### **CAUTION:**

- All electrical installations should be done in accordance with local electrical codes and the National Electrical Code (NEC), ANSI/NFPA 70.
- Before connecting the inverter to the electrical utility grid, your utility company must grant approval. Only qualified electricians should make the connection.
- When exposed to light, photovoltaic (PV) arrays create electrical energy that could cause a hazardous condition. To avoid this, completely cover the surface of all PV arrays with opaque (dark) material before wiring them.
- The inverter contains no user-serviceable parts. Refer maintenance to qualified service personnel.
- Do not touch the heat sink located at the top of the inverter, temperatures can exceed 158°F (70°C).

### **FCC Compliance:**

The PV Powered Grid Tied Residential Inverters have been tested and found to pass FCC Class B radio interference standards with proper installation of the inverter. This is not a guarantee that there will be no interference at every installation. If you notice interference at your installation, try the following potential solutions:

- Move or re-orient the affected device.
- Increase the distance between the devices.
- Connect the device to a different AC circuit.

**Please read all safety warnings and instructions before installing or operating the inverter.**

**SAVE THESE INSTRUCTIONS**

## **1 INTRODUCTION**

The PV Powered Grid Tied Residential Inverter is a utility interactive inverter for photovoltaic (PV) systems.

The inverter is tied to an electrical source provided by the local utility company as well as to the PV system. The inverter contains everything needed to convert the DC voltage generated by the PV arrays into the AC voltage required to power a house.

This manual provides information necessary for the successful installation and use of the PV Powered Grid Tied Residential Inverter.

## **2 INSTALLATION**

### **2.1 Selecting a Location for the Inverter**

When choosing a location for the inverter, consider the following criteria:

- The inverter is suitable for both indoor and outdoor installation; the inverter enclosure has a NEMA 3R rating.
- The optimum location of the inverter is outside, shielded from direct exposure to sunlight (i.e. not on the south facing side of the building).
- The heat sink temperatures can exceed 158°F (70°C). The inverter must be installed so that people will not touch the top of the unit.
- The inverter is designed to handle the temperature extremes of most climates. The operating and non-operating environmental ambient temperature range is -15°F to 105°F (-25°C to 40°C).
- The following clearances are recommended for proper placement of the inverter:
  - A minimum of 36" between the bottom of the inverter box and the ground.
  - A minimum of 12" above the heat sink.
  - Visibility of the operating LEDs and display located at the top front of the inverter box should also be considered.
- If the inverter is installed in an enclosed space, adequate ventilation must be provided.

### **2.2 Mounting the Inverter**

The inverter should be mounted vertically to a flat, solid surface such as wallboard, concrete, or wood siding. The inverter should be located near the PV arrays to minimize the DC wire length.

The mounting bracket provided makes mounting the inverter quick and simple. The 2 screw holes at either end of the bracket are 16" apart. Once the wall studs are located, anchoring the bracket becomes an easy task.

**WARNING:** Before drilling holes to mount the inverter, verify that there are no electrical wires or plumbing in the area.

## 2.2.1 Mounting the Inverter

1. Locate the wall studs in the desired location and align the mounting bracket over the studs. Mark the mounting holes. Ensure that locations A and B (see Figure 1) are aligned over the wall studs.
2. **VERIFY THE BRACKET IS LEVEL.** Ensure points A and B are aligned with the wall studs. Drill 1/8" pilot holes for the screws.
  - Use heavy-duty 1/4" x 2" coarse thread lag screws to secure points A and B to the wall.
  - Use an 1/8" screw to secure points C, D, E, and F (See Figure 1).

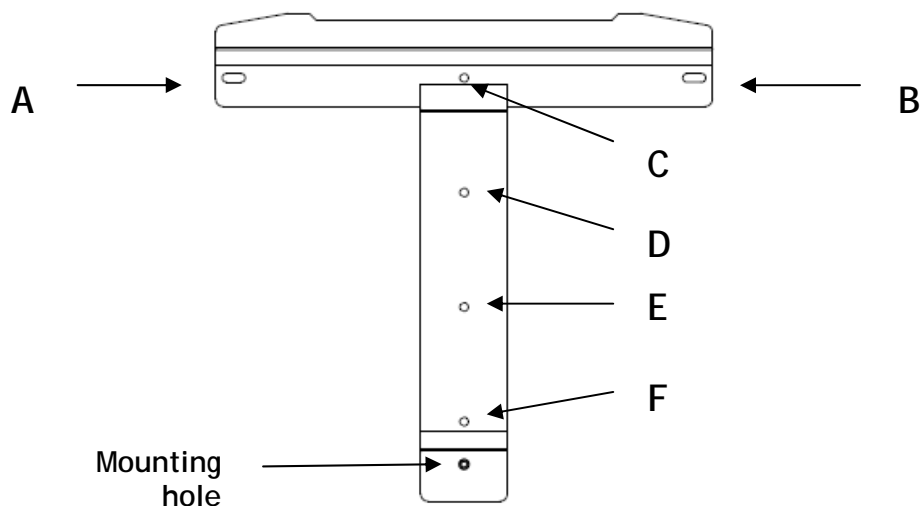

*Figure 1: Mounting Bracket*

3. Carefully hang the inverter on the upper part of the bracket. The hooks located at the rear of the inverter should hang over the bracket.
4. **Verify inverter is level.**
5. Remove the front cover of the inverter by unscrewing the four cover screws located around the front perimeter of the inverter.
6. Locate the inverter mounting hole below the power board. Insert the mounting screw through the inverter and tighten securely.



*Figure 2: Inverter with mounting bracket in place*

**NOTE:** Leave the inverter cover off to allow for electrical connections described in Section 2.3.

## 2.3 Electrical Connections

### CAUTION:

1. The National Electrical Code (NEC) requires that the inverter be connected to a dedicated circuit with no other outlets or devices connected to the same circuit. See NEC Section 690-64(b)(1). The NEC also places limitations on the size of the inverter and the manner in which it is connected to the utility grid. See NEC Section 690-64(b)(2).

See Table 2.1 for more information on required branch circuit protection.

2. To reduce the risk of fire, connect the inverter to the appropriate size breaker (See Table 2.1). Maximum branch-circuit over-current protection calculated in accordance with the National Electrical Code (NEC), ANSI/NFPA 70.

Inverter model	Circuit breaker required
PVP 1100	1 pole 15 A
PVP 2000	2 pole 15 A
PVP 2800	2 pole 20 A
PVP 3000	2 pole 20 A

*Table 2.1 Required Branch Circuit Protection*

### 2.3.1 Inverter Voltage and Frequency Limits

The inverter is factory-calibrated to the voltage and frequency limits specified in Table 2.2. This adjustable range can be set by PV Powered field technicians.

Condition	Factory setting (VAC) or (Hz)	Adjustable Range (VAC)	Maximum trip time(s)
Voltage phase high	132.0	132.0 - 142.0	< 1 second
Voltage phase low	105.6	95.6 - 105.6	< 2 seconds
Voltage phase fast high	144.0	144.0 - 156.0	< 160mS
Voltage phase fast low	60.0	<60.0	< 160mS
Voltage high Line to Line (240V inverters)	264.0		
Voltage low Line to Line (240V inverters)	211.0		
Voltage high Line to Line (208V inverters)	228.8		
Voltage low Line to Line (208V inverters)	183.0		
Line Frequency Low	59.3 Hz	n/a	< 160mS
Line Frequency High	60.5 Hz	n/a	< 160mS

Table 2.2 Voltage and Frequency Limits

Do not proceed with the electrical connection of the inverter until it has been properly mounted.

**WARNING:** Electrical connections must be completed in accordance with local electrical codes and the National Electrical Code (NEC), ANSI/NFPA 70. Use 10 AWG, minimum 90°C (194°F), copper wire for all inverter electrical connections. Voltage drop as well as other considerations may dictate using larger wire sizes.

**NOTE:** PV Powered recommends sizing wire of one percent voltage drop for AC and one percent voltage drop for DC.

**WARNING:** Make sure the main breaker in the main utility breaker box is switched OFF before wiring the inverter. This breaker should be switched ON only after all wiring has been completed as described in this manual.

**WARNING:** Follow the order listed below to wire the inverter. Failure to do so may result in hazardous voltages or disconnection of contacts.

**IMPORTANT:** When mounting the inverter outside, use rain-tight or wet-location conduit hubs that comply with the requirements in the Standard for Fittings for Conduit and Outlet Boxes, UL 514B.

Terminal connections for the inverter are located inside the inverter on the circuit board at the bottom of the cabinet. The AC and DC terminals accept wires up to 6 AWG.

**CAUTION:** The input and output circuits are isolated from the enclosure. System grounding, when required by Sections 690-41, 690-42, and 690-43 of the National Electric Code (NEC), ANSI/NFPA 70-1999, is the responsibility of the installer.



*Figure 3: Communications, AC, and DC ports*

### 2.3.2 Separation of Circuits

The lower part of the inverter circuit board is divided into three sections.

1. The left side is dedicated to the low voltage DC communications.
2. The center is dedicated to the AC.
3. The right side is dedicated to the DC.

Each section has two to three knockouts as shown in Figure 3. UL 1741 standard requires a straight run of wire, with no loops or crossover to the other circuits (sections) and low voltage versus high voltage in each section.

1. Left knockouts (up to the divider) are for low voltage communications only (PVM1010).
2. Center knockouts are for AC.
3. Right knockouts are for DC.

### 2.3.3 Grounding

A single-point ground connection is located in the lower right-hand side of the inverter cabinet. This is where the PV array grounding wire is terminated. The AC ground connection is terminated next to the Line 1 and Line 2 connections on the circuit board.

The PV ground connector is attached to the cabinet with a 10-32 bolt. This ground lug is provided to allow for the PV safety ground to be bonded to the cabinet. This is the only place the ground should be connected to the inverter.

- Do not tie the safety ground to the PV array positive or negative. That would defeat the ground fault protection circuit. (Refer to Figure 5.)
- See Table 2.3 for appropriate sizing of the grounding electrode. Use the maximum current AC or DC - whichever is larger - and multiply it by 1.25 to get the maximum current rating per NEC 690.

Maximum current rating	Minimum size of grounding electrode conductor AWG	
	Copper	Aluminum Copper clad
15	8	6
20	8	6
30	8	6
40	8	6
60	8	6

Table 2.3 Grounding Electrode Sizing

Figure 4 is a schematic representation of the PV Powered single-point grounding. The front cover is grounded through the cover mounting screws.

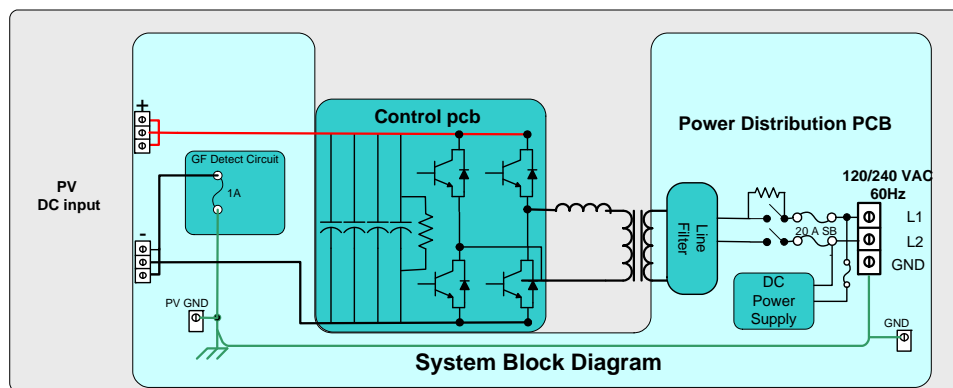

Figure 4: System Block Diagram showing single-point ground

### 2.3.4 GFI Circuit

The purpose of the Ground Fault Interrupter (GFI) circuit is to detect a ground fault (unintended current flow from the PV arrays to earth ground).

- For the GFI circuit to function as designed, the PV array safety ground must be connected only at the ground terminals provided.
- Bonding the safety ground to the grounded leg of the array anywhere but through the inverter will bypass the GFI circuit. This creates an unsafe operating condition.
- The GFI works by using a fuse to connect or bond the PV array negative (or the PV array positive if using a positively grounded array) to earth ground through the 1 A fuse.
- If current is greater than 1 A between the grounded array terminal and the earth ground, the fuse will “blow”. A “blown” or open fuse will disconnect the PV arrays from their ground reference and interrupt the ground fault current. In this situation, the inverter will cease operation and display a fault message (as illustrated below):

```

Fault 0400 0000
Ground Fault
    
```

If the inverter displays “Ground Fault”, turn OFF the AC and DC to the inverter and refer to the Troubleshooting section of this manual.

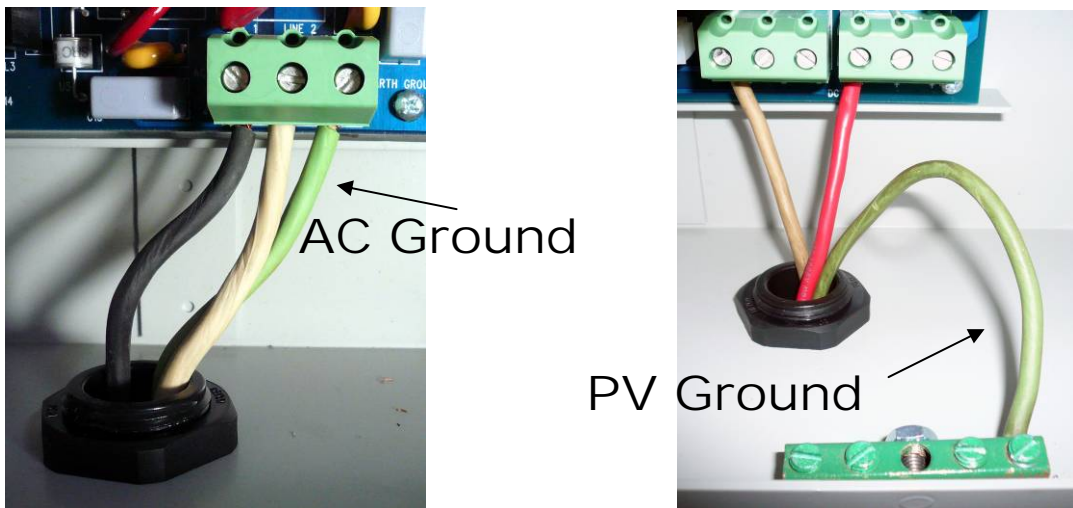

Figure 5: AC and PV Grounding

### 2.3.5 Connecting the Inverter to the Electrical Grid

Two circuit boards are located inside the Inverter:

- The Control Board (at the top of the inverter).
- The Power Distribution Board (at the bottom of the inverter) with the following terminals:
  - The AC connection terminal.
  - The DC connection terminal.
  - The internal Ground Fault Interrupt fuse.

**WARNING:** Replace the GFI fuse with the same type and rating of fuse. The inverter uses only Littelfuse KLKD001 1A/600V.

The inverter is connected to the electrical grid using 3 wires - LINE 1, LINE 2 and GROUND.

**NOTE:** To avoid an increase in AC voltage to unacceptable values while the inverter is connected, the grid impedance value at the connection point should be as low as possible. By keeping the grid impedance value low, the inverter will achieve higher system efficiency and avoid nuisance shutdowns. **The total impedance of the grid plus the interconnecting AC wires should be less than 1.25 Ohm.**

**WARNING:** Ensure the main 240V (or 208V for the PVP 2800) breaker at the circuit breaker panel is switched OFF before connecting to the AC terminal block.

To wire the inverter to the main utility grid, follow these steps (see Figure 6):

1. Run the conduit from the main breaker panel to the bottom of the inverter. Insert the fitting in the center opening of the inverter and fasten it with a locking nut.
2. Feed the LINE 1, LINE 2 and GROUND wires through the conduit and into a center opening of the inverter.
3. Connect the GROUND wire to the terminal marked "earth ground" inside the inverter.
4. Connect the LINE 2 wire to the terminal marked "line 2" inside the inverter.
5. Connect the LINE 1 wire to the terminal marked "line" inside the inverter.
6. Ensure all connections are wired correctly and properly torqued. Tighten the terminal block screws to 0.5 Nm (0.37 ft-lb).

**NOTE:** In the PVP1100 units, LINE 1 wire is the only phase voltage wire, LINE 2 is neutral, and LINE 3 is the AC GROUND.

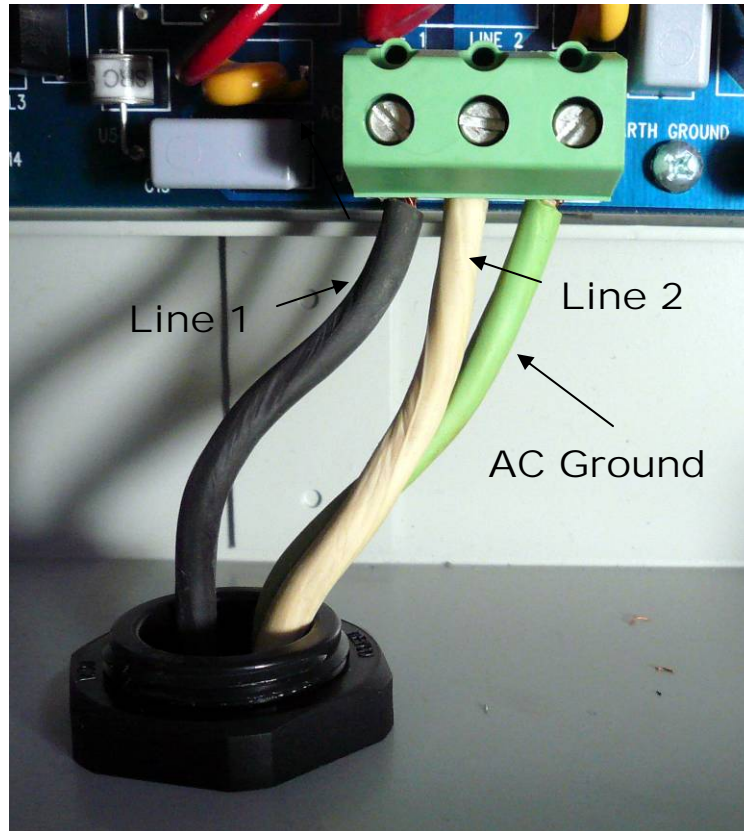

Figure 6: AC Wiring for the Line 1, Line 2, and Ground Wires

**WARNING:** Before proceeding with the DC wiring, completely cover the surface of all PV panels with dark material to avoid the production of electrical current.

**WARNING:** Make sure the polarity and the PV panel voltage between the positive and the negative cable connectors of the PV panels are correct before connecting the panels to the DC terminal block on the power distribution board.

The PV array open circuit voltage should be at or below the listed voltages in Table 2-4 under all circumstances. Each DC input to the DC terminal block must be less than the voltages listed in Table 2-4.

Inverter Model	Maximum inverter start voltage	Absolute maximum input voltage
PVP1100	450VDC	500VDC
PVP2000	450VDC	500VDC
PVP2800	450VDC	500VDC
PVP3000	450VDC	500VDC

Table 2.4: PV Open Circuit Voltages

### 2.3.5.1 Open Circuit Calculations

The PV array open circuit voltage should be at or below **500 VDC** under all circumstances. Each DC input to the DC terminal block must be less than 500 VDC.

### 2.3.5.2 DC Connections

Each DC input connection must carry the same input voltage. The inverter allows up to three connections for both the positive and negative poles.

To wire the DC inputs from the PV array to the inverter (see Figure 8):

1. Calculate the maximum open circuit voltage (Voc) for each series of modules based on the VOC\_TC, the ambient temperature, and accepted industry practice.

**Note:** For all temperature conditions, the Voc for each series connection **must** total less than the VDC indicated in Table 2-4 for the PVP1100, PVP2000, PVP2800, and PVP3000 models.

Review the PV panel's data sheet for operating temperature ranges.

2. Keep track of the array positive and negative leads and mark them clearly.
3. Route the PV array leads through the far right opening in the inverter.
4. Connect each series positive DC lead to the positive terminals of the power distribution board.

## WARNING:

**Negative grounded array:** On a standard negatively grounded PV array, only break only the positive wire(s) in the DC disconnect. Do NOT break the negative wire(s)..

**Positive grounded array:** On a positively grounded PV array, only break only the negative wire(s) in the DC disconnect. Do NOT break the positive wire(s).

5. Connect the negative DC leads directly to the negative terminal on the power distribution board.
6. Connect the ground wire(s) to the ground lug.

**WARNING:** Do not connect or disconnect the jumper while the inverter is supplied with DC or AC power.

7. Remove the 1 A fuse and select the negative or positive grounding jumper included with the inverter (see Figure 7).

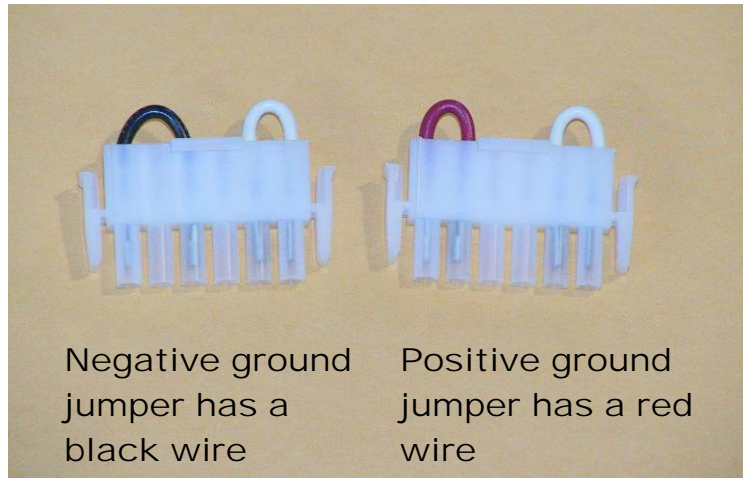
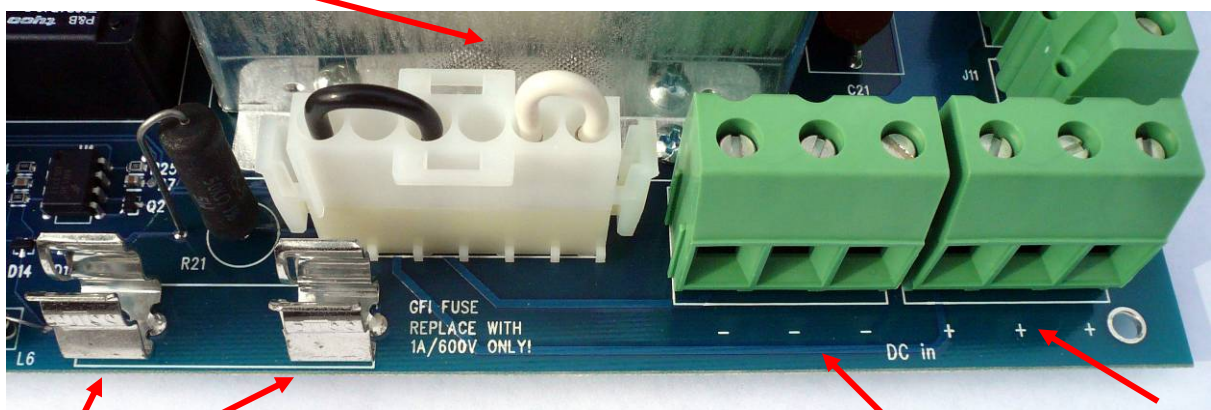

Figure 7 Grounding Jumpers

8. Install the grounding jumper with the white wire on the right into connector J3 on the power board (see Figure 8).

### GFI Jumper (J3)



Fuse Clips

Figure 8 Power Board Connections

PV Positive

PV Negative

9. Confirm that the DC disconnect is turned OFF and remove the material from the array.
10. With a voltmeter, check the PV array positive leads in the DC disconnect and confirm that the voltage is positive when referenced to the negative leads. The reading should match your series Voc total.

Measure the DC voltage potential between the two mounting clips (see Figure 8) for the 1 A fuse.

11. The voltage should be less than 25 volts absolute value. The DC and AC disconnect can be turned OFF and the 1 A fuse installed.
  - If the voltage is outside of this range (-25V to 25V), wait 10 minutes and check again.
  - If (after 10 minutes) the voltage is still not in the range of -25V to 25V, check for a ground fault or other incorrect wiring.
  - If the problem continues to persist, contact PV Powered Technical Support.

## 3 OPERATION

### 3.1 Start-Up Procedures for the Inverter

**WARNING:** Before turning ON the inverter, ensure that the front panel is closed properly.

**WARNING:** The heat sink can reach temperatures in excess of 158°F (70°C). Do not touch the heat sink when in use, and do not place anything on top of the heat sink.

To start up the inverter, complete the following steps in the order indicated:

1. Turn the **AC breaker ON**.
2. Verify that the RED LED light is illuminated.
3. Check the polarity to ensure the positive and negative are wired correctly, and confirm that the PV array open circuit voltage is at or below the level specified in Table 2-4.
4. Turn the **DC disconnect ON**.

**Note:** PV Powered recommends that a padlock be attached to prevent unauthorized access or damage to the inverter.

5. After five minutes, the inverter will start to produce power if all necessary operating conditions are met.

### 3.2 Inverter Front Panel Status Indicators

#### 3.2.1 LED Indicator Lights

The inverter has two LED indicator lights visible through the upper left corner of the front panel. These lights indicate the inverter's status.

- If the inverter's operating environment is safe to export power into the AC grid, the GREEN LED is illuminated.
- If the operating environment moves outside the safe operating limits governed by UL 1741, IEEE 1547, IEEE 519, and NEC 690, the RED LED indicator is illuminated.

The inverter continuously monitors:

1. The AC grid connection, to ensure the AC voltage and frequency levels are within safe operating limits per UL1741.
2. The DC voltage and current from the PV array ensuring safe operating conditions per UL 1741.

3. The inverter's internal operational parameters, to ensure safe operating conditions exist within the operating environment.

If all three conditions are met, the inverter displays the GREEN LED.

If any one of the operating conditions are not met, there is a fault condition. The inverter will then flash the RED LED.

A solid RED LED illuminates when the PV array voltage is not within safe operating limits. The following conditions may cause this to occur:

- At sunset, when the inverter turns OFF for the night.
- When clouds reduce the amount of available sunlight or when portions of the PV array are covered with snow.
- Any time the DC output from the PV array drops below the inverter's minimum DC operating voltage, the inverter turns OFF.

When the array is once again exposed to enough sunlight, the GREEN LED illuminates, the inverter's auto-start feature begins, and after five minutes the inverter begins to export power.

If the RED LED continues to illuminate when there is sufficient sunlight for operation, verify that no wiring connections are loose. If the wiring is tight, see the Troubleshooting section of this manual.

### 3.2.2 Vacuum Fluorescent Display (VFD)

The vacuum fluorescent display (VFD) indicates the inverter's status and real-time power output into the AC Grid. This display provides the following information:

- Inverter model number.
- AC power produced in real-time (Watts).
- Lifetime energy produced (kWh).
- AC voltage in real time (VAC).
- PV voltage input in real-time (VDC).
- During start-up, a count down timer.
- Fault code message if a fault exists or recently occurred.

### 3.2.2.1 *Normal Display Cycle*

The display will change screens every two seconds to show a different set of information.

Normal startup:

2000 Watt PV Start in 269 sec
0 Watts 3212 kWh
240 VAC 297 VDC

Running:

2000 Watt PV Grid Tied Inv
1245 Watts 3212 kWh
241 VAC 255 VDC

If a fault occurs, the display also provides a corresponding fault code. Refer to the Troubleshooting section of this manual.

## **4 TROUBLESHOOTING**

The inverter provides two indicator lights that help troubleshoot problems.

- The light on the left is a RED LED.

The RED LED illuminates any time the DC voltage is below the inverters startup DC voltage, such as at night. The RED LED blinks if the inverter has had a fault condition, and the vacuum fluorescent display (VFD) displays a fault code. Possible faults are listed in this Troubleshooting section.

- The light on the right is a GREEN LED.

The GREEN LED illuminates any time the DC voltage is above the inverter's DC start voltage and all operational parameters are met. When the GREEN light illuminates, the inverter tries to invert power from the PV array.

### **4.1 Red and Green LED Lights ON**

If this condition occurs (both lights are on solid at the same time), contact PV Powered for technical assistance.

## 4.2 Displayed Fault Codes

The vacuum fluorescent display (VFD) provides the following codes when a fault has occurred:

Faulted:

Fault 1000 0400 AC Voltage High
0 Watts 1400 kWh
267 VAC 300 VDC

Starting up from a faulted state:

2000 Watt PV Start in 269 sec
Fault 1000 0400 AC Voltage High
0 W 1400 kW-hr
240 VAC 300 VDC

NOTE: In this case the fault refers to the last fault detected.

If the inverter is in a faulted state, the RED LED blinks and the VFD scrolls through the screens shown in the faulted example above. The text of the fault describes the specific fault condition that the inverter experienced.

If the inverter is no longer experiencing the condition that caused it to fault (ex. the AC voltage climbs above 264V then drops below 264V), the RED LED stops blinking and the inverter starts the five minute count-down timer. During these five minutes, the display will also show the last fault.

### 4.2.1 Multiple Faults

If the inverter detects multiple faults at one time, the inverter displays the text of the first fault detected.

For multiple faults, the numerical values of the fault codes are added.

Example:

Fault 1000 0420 AC Voltage High
------------------------------------

The above example displays the AC Voltage High fault (1000 0400), plus a DC Voltage Low fault (1000 0020). This might occur at night, when the panel voltage is low (because of darkness) and the utility voltage was above the limits defined in Table 2.2.

Fault 1200 0040  
Power Low

The above example shows a Power Low fault. After the fault occurrence, the inverter had a DC Voltage High fault. In this case, the display added the fault codes 0200 0000 plus 1000 0040 to become 1200 0040.

If the faults have the same first digit – such as 1000 XXXX – the 1 remains the same and only the second block of four numbers will add to the original fault code.

#### 4.2.2 Fault Code List

Fault Code	VFD Text	Fault Description
8000 0000	Power Module	Generated by the power electronics module to protect the module.
4000 0000	Power Module	Generated by the power electronics module to protect the module.
1000 0800	PLL Fault	The inverter was unable to match the grid frequency. This is usually caused by an unstable power grid.
1000 0400	AC Voltage High	The grid voltage exceeded the limits in table 2.2.
1000 0200	AC Voltage Low	The grid voltage dipped below the AC limits in table 2.2.

Fault Code	VFD Text	Fault Description
1000 0100	AC Freq Low	The grid frequency went below the limits in table 2.2.
1000 0080	AC Freq High	The grid frequency went above the limits in table 2.2.
1000 0020	DC Voltage Low	The DC voltage is below the startup voltage. This fault is only seen in conjunction with another fault (ex. 1000 0220 is an AC low and a DC low). DC could be low because of low light conditions or the DC disconnect is turned off.
1000 0010	DC Voltage High	DC Voltage is above 500V. Turn the DC disconnect off immediately. The inverter will restart when the voltage is back within safe operating conditions.
1000 0002	Power Supply +15	Housekeeping DC power supply 15VDC is out of tolerance.
1000 0001	Power Supply +5	Housekeeping DC power supply 5VDC is out of tolerance.
0400 0000	Ground Fault	The inverter detected that the GFI fuse is blown. Check section 4.2 to troubleshoot. This fault requires an AC power cycle to reset.
0200 0000	Power Low	The inverter shut down because it was producing less than 60W for 5 minutes. It will try to restart in 10 minutes.

0100 0000	CPU Fault	The inverter encountered a problem in the CPU. This fault requires an AC power cycle to reset. If this fault happens again contact PV Powered for service.
0040 0000	Over Current	Safety protection; the inverter tried to produce too much current.
0020 0000	Pre-charge	The inverter experienced trouble starting up the transformer. If this happens again, contact PV Powered.
0004 0000	Heatsink Temp	The heat sink is above or below the operating limits of -15°F to 200°F (-25°C to 95°C).
0002 0000	Watchdog Fault	The CPU experienced a watch dog fault. This fault requires an AC power cycle to reset. If this occurs again contact PV Powered.
0001 0000	Ambient Temp	The temperature detected inside the inverter is outside the normal operating limits of -15°F to 200°F (-25°C to 95°C).

**WARNING:** These servicing instructions are for qualified personnel only. To reduce the risk of electric shock, do not perform any servicing other than that specified in the operating instructions unless you are qualified.

## 5 SPECIFICATIONS

### 5.1 Operational Specifications

The specifications detailed below are expected operational parameters, and should be used in designing your PV system in accordance with the NEC.

Specifications	PVP1100-120 EV	PVP1100-120	PVP2000-240 EV	PVP2000-240	PVP2800-208	PVP3000-240
Maximum DC Input Voltage (VOC)	500VDC					
DC Voltage Operating Range (V)	115VDC-450VDC	150VDC-450VDC	115VDC-450VDC	150VDC-450VDC	180VDC-450VDC	170VDC-450VDC
DC MPPT range (V)	115VDC-380VDC	150VDC-380VDC	115VDC-380VDC	150VDC-380VDC	180VDC-380VDC	170VDC-380VDC
DC Imp Maximum Current (A)	10A	8A	18A	14A	17A	18A
DC Isc Maximum Current (A)	26A		26A			
AC Operating Range (V)	105.6V-132.5V	105.6V-132.5V	211V-264V	211V-264V	183V-228.8V	211V-264V
AC Frequency Range (Hz)	59.3Hz-60.5Hz					
AC Nominal Voltage (V)	120V	120V	240V	240V	208V	240V
Normal Output Frequency	60Hz					
Synchronization in rush current	<2.0A					
Power Factor	0.99 - 1.0 at >50% Power					
AC Maximum Continuous Current (A)	9.5V	9.5A	9A	9A	14A	13A
Recommended Breaker Size	15	15	15	15	20	20
Output Overcurrent Protection	20A					
Continuous Output Power (Watts)	1100	1100	2000	2000	2800	3000
Maximum Continuous Output Power (Watts)	1100	1100	2000	2000	2800	3000
Enclosure	Aluminum-NEMA 3R to UL 50 Standards					
Dimensions (WxDxH)	15" x 7.5" x 21.75"					
Weight	55	55	65	65	80	80
Cooling	Natural Convection					
Relative Humidity	0% to 100% Condensing					
Ambient Temperature Range	-25°C to +40°C					
Environmental Rating	NEMA 3R					
Listings	UL 1741, IEEE 1547, IEEE 519, IEEE 929, IEEE 620					

## 5.2 Abnormal Specifications

The specifications listed below are classified as abnormal and are not representative of normal operation.

Abnormal Specifications	PVP1100-120 EV	PVP1100-120 SV	PVP2000-240 EV	PVP2000-240 SV	PVP2800-208	PVP3000-240
Momentary current transient obtained during abnormal operation	100 A-pk / 0.54 mS		142 A-pk / 0.663 mS		50 A-pk for 0.600 mS	166 A-pk / 0.608 mS
Maximum input source backfeed current to input source	0A					

## **6 LIMITED WARRANTY**

PV Powered, Inc. provides a limited warranty for your residential or commercial inverter and optional data monitoring module for defects caused by material or manufacturing flaws. The inverter and the data monitoring module must be installed and maintained by a qualified installer in order for the warranty to be valid.

### **6.1 Term of Coverage**

The warranty period for the inverter is ten years, and the warranty on the data monitoring module is one year, each beginning on the date of purchase by the original end user.

### **6.2 Coverage**

PV Powered will, at its option, repair or replace the defective component(s) free of charge, provided that you notify PV Powered of the defect during the warranty period, have a dated proof of purchase, and PV Powered determines that the defect is covered by the limited warranty set forth above. PV Powered reserves the right to inspect the defective component(s) and determine if the defect is due to material or manufacturing flaws. PV Powered also reserves the right to charge a fee for service time expended if the defect is not due to material or manufacturing flaw or is not for some other reason subject to this limited warranty.

PV Powered will, at its option, use new and/or reconditioned parts in performing warranty repair and in building replacement products. PV Powered reserves the right to use parts or products of original or improved design in the repair or replacement. If PV Powered repairs or replaces a product, its warranty continues for the remaining portion of the original warranty period or 90 days from the date of the return shipment to the customer, whichever period expires later. All replaced products and all parts removed from repaired products become the property of PV Powered.

For defects covered by this limited warranty, PV Powered will provide, at no additional cost to the customer, both parts and labor necessary to repair the product, and return shipment to the customer via a PV Powered selected, non-expedited, surface freight carrier within the United States and Canada.

### **6.3 What is Not Covered**

PV Powered does not warrant its products from any and all defects or damage caused by:

- Normal wear and tear.
- Shipping or transportation damages.
- Improper installation.
- Improper maintenance.
- Excessive voltage or current conditions from the electrical grid or PV panels.

- Exposure to unsuitable environmental conditions (including but not limited to damage due to lightning strikes, storm, fire, flood, etc.).
- Unauthorized or abnormal use, repair, modification, or operation.
- Negligence or accidents.
- Material or workmanship not provided by PV Powered or its authorized service centers.

This warranty also does not cover costs related to the removal, installation, or troubleshooting of your electrical systems.

## **6.4 Disclaimer and Limitation of Liability**

EXCEPT FOR THIS EXPRESS LIMITED WARRANTY, PV POWERED EXPRESSLY EXCLUDES ALL WARRANTIES WITH RESPECT TO THE INVERTER AND DATA MONITORING MODULE, EXPRESS AND IMPLIED, INCLUDING BUT NOT LIMITED TO THE WARRANTY OF MERCHANTABILITY, THE WARRANTY OF FITNESS FOR A PARTICULAR PURPOSE, AND ANY WARRANTIES THAT MAY HAVE ARISEN FROM COURSE OF DEALING OR USAGE OF TRADE.

TO THE MAXIMUM EXTENT PERMITTED BY LAW, PV POWERED'S AGGREGATE MONETARY LIABILITY TO THE CUSTOMER FOR ANY REASON AND FOR ANY AND ALL CAUSES OF ACTION, WHETHER IN CONTRACT, TORT OR OTHERWISE, WILL NOT EXCEED THE AMOUNT PAID TO PV POWERED FOR THE INVERTER OR DATA MONITORING DEVICE. PV POWERED WILL NOT BE LIABLE TO YOU UNDER ANY CAUSE OF ACTION, WHETHER IN CONTRACT, TORT OR OTHERWISE, FOR ANY INDIRECT, SPECIAL, INCIDENTAL, CONSEQUENTIAL, OR PUNITIVE DAMAGES, EVEN IF PV POWERED HAS BEEN ADVISED OF THE POSSIBILITY OF SUCH DAMAGES. THE ORIGINAL PRICE FOR THE INVERTER AND DATA MONITORING MODULE AND PV POWERED'S OBLIGATIONS UNDER THIS EXPRESS LIMITED WARRANTY ARE CONSIDERATION FOR LIMITING PV POWERED'S LIABILITY.

IF THIS PRODUCT IS A CONSUMER PRODUCT, FEDERAL LAW DOES NOT ALLOW AN EXCLUSION OF IMPLIED WARRANTIES. TO THE EXTENT YOU ARE ENTITLED TO IMPLIED WARRANTIES UNDER FEDERAL LAW, TO THE EXTENT PERMITTED BY APPLICABLE LAW THEY ARE LIMITED TO THE DURATION OF THIS LIMITED WARRANTY. SOME STATES AND PROVINCES DO NOT ALLOW LIMITATIONS OR EXCLUSIONS ON IMPLIED WARRANTIES OR ON THE DURATION OF AN IMPLIED WARRANTY OR ON THE LIMITATION OR EXCLUSION OF INCIDENTAL OR CONSEQUENTIAL DAMAGES, SO THE ABOVE LIMITATION(S) OR EXCLUSION(S) MAY NOT APPLY TO YOU. THIS LIMITED WARRANTY GIVES YOU SPECIFIC LEGAL RIGHTS. YOU MAY HAVE OTHER RIGHTS WHICH MAY VARY FROM STATE TO STATE OR PROVINCE TO PROVINCE.

## **6.5 Arbitration**

IN THE EVENT OF A DISPUTE BETWEEN PV POWERED AND ANY PURCHASER COVERED UNDER THIS WARRANTY, TO THE MAXIMUM EXTENT ALLOWED BY LAW, THE PURCHASER AGREES TO RESOLVE ANY AND ALL SUCH DISPUTES USING BINDING ARBITRATION IN ACCORDANCE WITH THE RULES AND PROCEDURES OF THE ARBITRATION SERVICE OF PORTLAND, INC., AND JUDGMENT UPON AWARD

RENDERED PURSUANT TO SUCH ARBITRATION SHALL BE BINDING ON THE PARTIES. THE LOCATION FOR ANY ARBITRATION HEARINGS SHALL BE BEND, OREGON. THE PRICE FOR THE INVERTER OR PVM1010 DEVICE AND PV POWERED'S OBLIGATIONS UNDER THIS EXPRESS LIMITED WARRANTY ARE CONSIDERATION FOR THIS BINDING ARBITRATION PROVISION.

## **6.6 Miscellaneous Provisions**

This limited warranty will be governed and interpreted exclusively in accordance with the laws of the state of Oregon, without reference to provisions concerning conflicts of laws. If any provision of this limited warranty is found by any court or arbitrator to be invalid, illegal or unenforceable, the validity, legality and enforceability of the remaining provisions will not be affected thereby. This limited warranty constitutes the entire contract between the parties concerning the subject matter of this warranty and supersedes all marketing brochures and other expectations, understandings, communications, representations and agreements, whether verbal or written, between the parties.

## 7 RETURN PROCEDURE

Before returning the product directly to PV Powered, you must first obtain a **Return Materials Authorization Number (RMA)** from PV Powered. You must also pre-pay for shipping. When you contact a PV Powered representative, please have the following information ready:

1. The serial number of the product
2. The reason for the return
3. A copy of your dated proof of purchase

When you return the product to PV Powered, PV Powered advises that you use the original packaging or its equivalent, and that you fully insure the shipped product. PV Powered is not responsible for damage to the product due to improper packaging.

On the packaging, please include the following:

1. Clearly mark the **Return Materials Authorization Number** (supplied by PV Powered) on the outside of the box.
2. A return address where the product can be shipped.
3. A telephone number where you can be reached during business hours.
4. A brief description of the problem.

Ship the product *prepaid* to the address provided by your PV Powered representative.

### 7.1 Information about Your System

Note the following information for your records, and retain your dated proof of purchase:

Serial Number \_\_\_\_\_

Purchased From \_\_\_\_\_

Date of Purchase \_\_\_\_\_





