

Solar Power System Installation Manual



Power-Save Energy Co. 3940-7 Broad St. #200 San Luis Obispo, CA 93401 866 297 7192

FOR INSTALLATION PERSONNEL

- Please read this manual carefully before installing the system and carry out the installation procedures correctly.
- This manual does not list all precautions needed for safe work. Be sure to follow OSHA guideline.
- This manual provides guidelines for installation, but it does not guarantee the quality of installation work. Please complete all work in a responsible and professional manner. Electrical work should be performed by a qualified electrician.

1 FOR SAFE INSTALLATION WORK

The system should be installed only by individuals who have training or previous experience installing PV Systems. All required licenses and certifications as well as safety standards must be adhered to.

WARNING

- Do not cut or modify Mounting System. Doing so is dangerous. Safety cannot be guaranteed.
- Do not work during stormy weather. Solar modules can be caught in the wind, causing you to fall.

CAUTION

- Never step or sit on the glass surface of a solar module. The glass may break, resulting in shock or bodily injury. The module may also stop generating power.
- Always use the supplied parts to attach the solar modules and mounts. Use of weaker parts, such as screws that are too short, is dangerous and may cause the solar modules or mounts to fall.
- Always use the specified tools. The solar modules or mounts may fall if the installation is not strong enough, for example when parts are not tightened sufficiently.
- Regardless of whether you are working on a new or existing roof, never allow the sheathing to become wet. Protect the sheathing from rain during the installation. Failure to do so may cause leaks.
- Always use the specified materials. Use of other materials is dangerous. Materials other than specified can reduce performance and can cause leaks, shock, and so on.
- Do not modify or cut parts.
- Do not install in corrosive locations classified C5 by ISO.
- Protective earth grounding of the individual photovoltaic modules is achieved by securing the modules to the mounting frames. The assembly instructions should be closely followed, in order to ensure a reliable ground connection.

UL REQUIRED INFORMATION:

1. Artificially concentrated sunlight shall not be directed on the module.
2. "Rated electrical characteristics are within 10 percent of measured values at Standard Test Conditions of: 1000 W/m², 25°C cell temperature and solar spectral irradiance per ASTM E 892 or irradiation of AM 1.5 spectrum."
3. Under normal conditions, a photovoltaic module may experience conditions that produce more current and/or voltage than reported at Standard Test Conditions. Accordingly, the values of ISC and VOC marked on UL Listed modules should be multiplied by a factor of 1.25 when determining component voltage ratings, conductor capacities, fuse sizes and size of controls connected to the module output. Refer to Section 690-8 of the National Electric Code for an additional multiplying factor of 1.25 which may be applicable.
4. Wiring methods should be in accordance with the NEC.
5. Install wires and cables with appropriate hardware in accordance with applicable electrical codes.
6. Protective earth grounding of the individual photovoltaic modules is achieved by securing the modules to the mounting frames. The assembly instructions should be closely followed, in order to ensure a reliable ground connection.
7. The framing system shall be grounded in accordance with NEC Article 250.
8. #10 AWG copper wire is the minimum size acceptable for the primary protective ground connection to the rails.
9. A UL Listed Grounding terminal constructed of tin-plated copper or stainless steel, or steel provided with a zinc or beryllium coating, and suitable for outdoor use, shall be used with the selected grounding wire (minimum 10 AWG copper wire).
10. All of the Rails in an installation shall be provided with protective earth bonding wires when installed.
11. The framing system has only been evaluated by UL for use with the photovoltaic modules listed in this manual.

1.1 CAUTIONS REGARDING INSTALLATION OF SOLAR POWER

SYSTEMS

This manual contains critical information regarding electrical and mechanical installation and safety information that you should know before starting installation.

Do not locate systems near coastal locations or other saltwater locations or C5 locations as classified by ISO. Minimum distance is 0.3 miles from the body of water.

Do not locate in a corrosion prone area. The modules and system are UL listed to standard 1703. The UL 1703 test is performed at 1.5 times the design load of 30 lbs per square foot, or 45 lbs per square foot.

CAUTION

1. Do not drill holes in frame. Do not cut or modify parts or rails.
2. Work under dry conditions with dry tools.
3. Do not stand or step on solar module.
4. Do not install near flammable gases.
5. Do not drop or allow objects to fall onto module.
6. Completely cover solar module with opaque materials when wiring to halt production of electricity.
7. Keep the backside of solar module surfaces free of foreign objects.
8. Do not use chemicals on solar modules when cleaning.
9. Do not wear metallic jewelry, which may cause electrical shock.
10. Do not touch cable electrical contacts.
11. Do not expose solar modules to sunlight that is concentrated with mirrors, lenses or similar means.
12. Consult local codes and other applicable laws and statutes concerning required permits and regulations concerning installation and inspection requirements. Install solar modules and systems according to applicable codes.
13. Product should be installed and maintained by qualified personnel. Keep unauthorized personnel away from solar modules.
14. Avoid shadowing cells in order to prevent solar module hot spots and/or reduction in power.
15. Avoid installing modules and mounting system in high corrosion areas.

1.2 PV MODULES

WARNING: Wiring work should be performed according to the provisions of the National Electrical Code. The grounding work and wiring connections to the inverter should be performed by a qualified electrician.

Adhere to all NEC. Pay special attention to Article 110, Chapter 2, Article 250, Chapter 3, Articles 300 & 310, 480 & 690.

The solar array generates electricity whenever it is exposed to sunlight. Be careful when handling it. There is a danger of shock if you touch the

connectors or wires of the electric cables.

1 Points to check before wiring.

- The solar modules generate electricity when exposed to light. You will need to wear insulating gloves.
- You will need a multi-meter for volts, amps, resistance and continuity capable of measuring DC and AC up to 600V and 40A.
- Make sure your tools are insulated.

2 Wiring the solar modules.

- Never step or sit on the glass surface of the solar modules. The glass may break.
- When you install the solar modules on the mount, never allow an output cable to become caught between the mount and a module frame.
- The solar modules generate electricity when exposed to sunlight, take care not to short circuit the output cables. The cables can become overheated and their cable sheaths can melt.
- Ensure the module connectors are fully inserted. There is a risk of malfunction if they are not pushed in all the way.
- Support output cables so that there is no slack. High winds can blow slack cable against the mount, damaging the cables.

3 Wiring from solar arrays to the inverter (connector box).

- Follow the provisions of the National Electrical Code. Adhere to all of the NEC. Pay special attention to Article 110, Chapter 2, Article 250, Chapter 3, Articles 300 & 310, 480 & 690.
- For wiring through walls, protect the cables with metal conduits, flexible metal conduits, or other protection. Failure to do so can result in shock and short circuits. Always use conduit to protect sections of array output cables that are exposed to sunlight. For wiring outdoors, protect cables with PVC conduits, metal conduits or flexible conduits.
- Prevent water from entering or building up in conduit by using waterproof fittings or duct seal.
- To prevent shock, tape and label the cut ends of array output extension cables (the side opposite to the connector side) before connecting to solar module output cables. Further, tape them again after measuring the voltage of each array.
- To prevent shock when you connect the array output cables to the inverter, remove the tape one cable at a time as you connect the cables.

4 Measuring array output voltage

- See the description of how to measure the output voltage for each array.
- Make sure that all solar modules are exposed to sunlight. (Remove lightproof sheets, if present.)
- Set the volt meter measurement range to a DC voltage, greater than the expected measurement (for example 600 VDC).
- Keep the plus (+) solar array output cables away from the ends of the minus (-) cables. Dangerous arcs can occur. (The array output voltage under normal

conditions (clear skies) can be very high.)

5 Grounding the mount

- To prevent shock, always connect a ground wire from the mounting hardware to earth.
- Use a minimum #10 AWG ground wire. Run a continuous bond wire to each module and rail in the array. Refer to section on grounding in this manual.
- Follow NEC 690 grounding provisions.

2 POINTS TO CHECK WHEN SELECTING THE INSTALLATION LOCATION

Check the following items before starting installation work. Refer to the inverter installation manual for more information about inverter installation and electrical work.

2.1 CONDITION OF HOUSE WHERE SOLAR POWER SYSTEM IS TO BE INSTALLED

INSPECTION OF ROOF STRUCTURE

It is important to inspect the structural integrity of the roof and the durability of the roof materials. The SRS mounting structure and solar modules require a strong base for durable and reliable operation in local environments. Always wear a safety harness when working on the roof.

Inspect the roof surface in the area of the installation for cracks, water leakage, and roofing material quality and uniformity. This is especially important if the roof is older than 10 years.

Inspect the roof for sags and other abnormalities. A sag or deep depression in the roof may indicate a structural weakness in the support system that may require correction. The following illustrations detail typical roof construction as well as old roof problems.

INSPECTION OF THE ROOF SUPPORT SYSTEM

This may require access to the attic. Check that all rafters, trusses and other materials are in good condition. Check for indication of previous water leaks. Measure the spacing of the rafters or trusses to confirm the dimensions and prepare for the system layout. Determine the location of the electrical roof penetration and wire run, if wiring is planned for this area.

1. Install solar modules facing south, if possible. Installations facing east and west are also possible, although the amount of power generated will be lower. Check the roof from a southern orientation, and check for obstacles that will cast a shadow. These factors will lower the amount of power generated. Explain this to the users and obtain their consent.

2. Install in a location that has good sun exposure throughout the year. Less power is generated in shaded locations.

3. Check the following before installation.

3.1 Solar modules should not be installed within 12" from the ridge or edges of the roof, nor within 16" from the eave.

3.2 Installation is not possible in regions where the wind pressure exceeds 45 PSF. Check with your local building department to determine if this mounting system is in compliance. Installation is not possible when the roof angle is less than 10 degrees or greater than 45 degrees.

3.3 Do not locate systems near coastal locations or other saltwater locations or C5 locations as classified by ISO. Minimum distance is 0.3 miles from the body of water. The array must be installed at least 16" away from the eave of the roof and 12" from the sides of the roof. This border will enhance the wind load resistance of the system.

4. The output of a series string of solar modules is connected to the input of the inverter. Always install solar modules so that all elements of the array receive the same amount of sunlight. The amount of power generated declines dramatically if you connect solar modules receiving different amounts of light in a string array, for example, solar modules facing east and solar modules facing south should not be connected in the same string. Refer to the inverter installation manual for more information about the number of solar modules connected in series in a single array.

5. It may not be possible to install solar modules in the following areas and under the following conditions. For more information, contact technical support.

- Regions with heavy snowfall - Installation is not possible in regions where snow accumulation exceeds the maximum allowable load. Contact the building department for more information about maximum snow accumulation.

3 PARTS

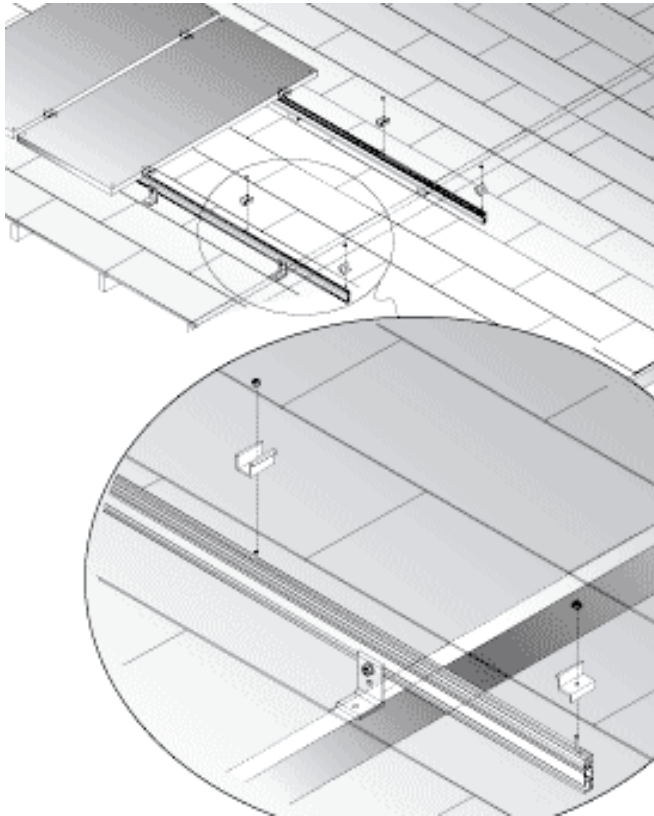

Accessory List

Item #	Descriptions	PCS / Kit
1	L-Feet	16
	3/8-16*7/8 screw	16
	3/8 screw nut	16
2	Mid clamps	8
	1/4-20*2-1/4 screw	8
	1/4 screw nut	8
3	splice kit	4
	3/8-16*7/8 screw	16
	3/8 screw nut	16

4	End clamps	8
	1/4-20*3/4 screw	8
	1/4 screw nut	8
5	ground lug	6
	1/4-20*16 screw	6
6	51_length rack	8
Total		152

5. Ground Lug

6. Rail 1. L Feet

4. End Clamp 2. Mid Clamp



3. Splice kit

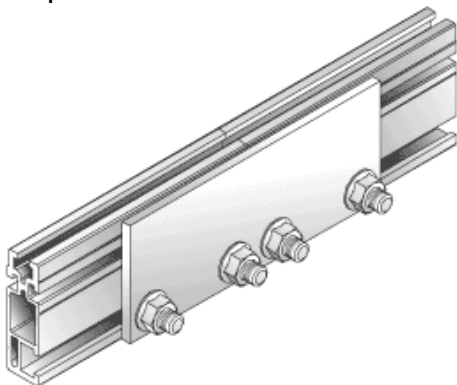

ASSEMBLY

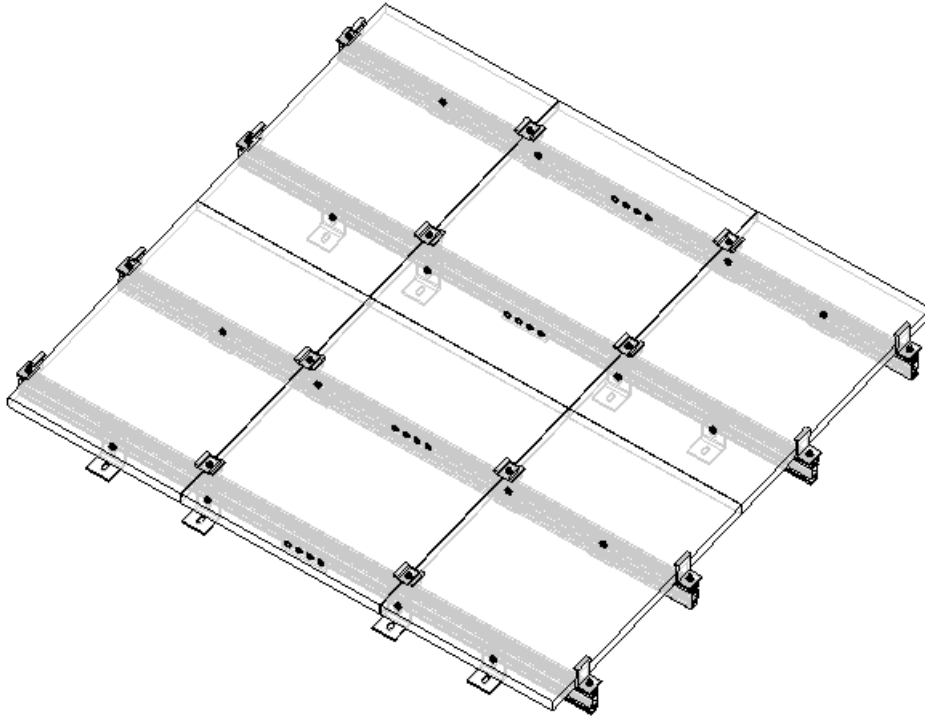

NOTE LAYOUT IS 2 SETS OF 3 PANELS

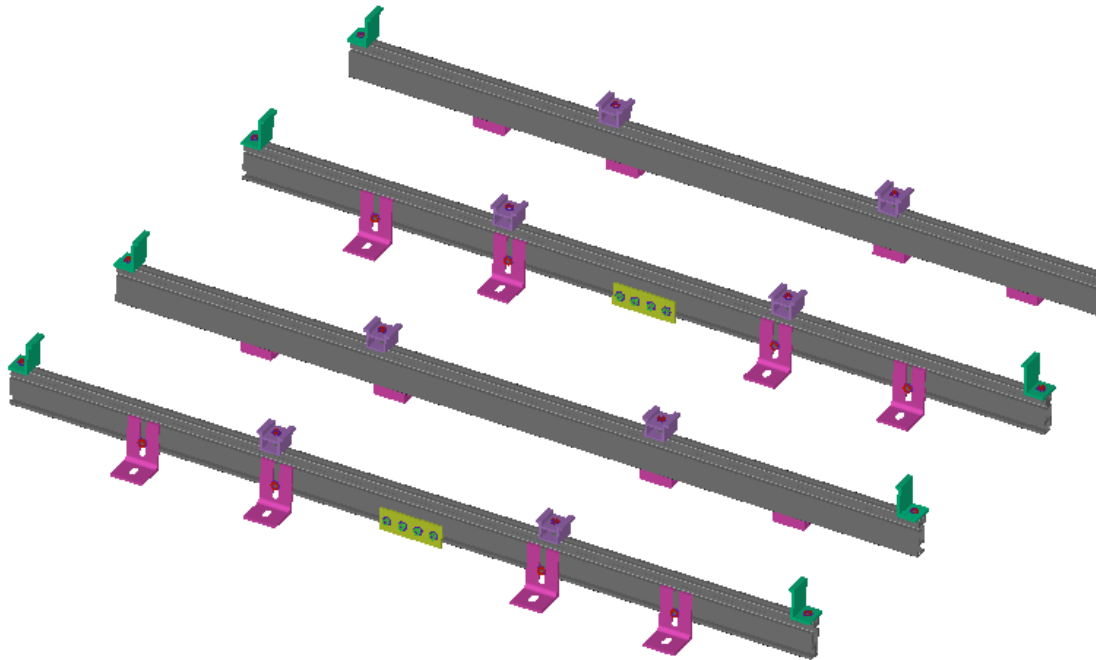

4 POINTS TO CHECK BEFORE INSTALLATION WORK

WARNING

- The solar modules generate electricity when exposed to sunlight, so be careful not to short circuit the output cables. The cables can become overheated and their cable sheaths can melt.
- Stop working when the surface of the roof is wet. There is a danger of slipping, falling, and shock.

CAUTION

- Never step or sit on the glass surface of the solar modules. The glass may break.
- Do not twist the solar modules when you mount them (twisting should not exceed 0.1" per 4"). Failures and damage can result.
- When you mount the solar modules on the rail, never allow an output cable to become caught between the rail and a module frame. Short circuits and fire can result.

4.1 UNPACKING AND CHECKING PARTS

When you unpack the system, check the model names of the components of each system and check to be sure that you have the correct number of parts.

4.2 MATERIALS AND TOOLS YOU WILL NEED

Before starting installation work, make sure you have the following materials and tools on hand (including materials and tools for electrical work).

MATERIALS

Ground wire, Ground Rod Electrical tape
Flexible metal conduit (to protect electric cables)
Cable ties
Pencil
Cordless drill
Socket drivers
Phillips driver bits
Drill
Screwdriver set
Needle nose pliers
Lineman's pliers
Wire cutters
Hammer Chisel
Crimping tool
Knife
Tape measure
Extension cord

Chalk line
Gloves & safety helmet
Rope Tool belt Ladders Safety Harness
Compass
Calculator
Solar insulation meter
Digital multi-meter

5 INSTALLATION WORK

5.1 PREPARING SHINGLE / COMPOSITE ROOF FOR INSTALLATION

1. Locate roof rafters or trusses. Tip: here are 3 options to finding the locations.
 - A. Locate and measure the locations of the rafters in the attic or at the outside eave and transfer measurements to the roof.
 - B. Use a rubber or leather mallet to tap the roof and locate the rafters. This will work with a cap sheet or composition roof.
 - C. Scan the roof with a high sensitivity stud finder.
2. Once the rafters have been located, snap a chalk line on every rafter to identify the location.
3. Measure up from the eave 16" (400 mm) in at least 3 locations. Snap a chalk line. This marks the location of the bottom edge of the slider feet. Note: This line needs to be 0.22" (5.5 mm) away from the nearest front edge of shingles.
4. Measure up from chalk line 0.8" (20 mm) and snap a new chalk line. This marks the location of the bottom edges of the modules.
5. Measure up from the module chalk line to the desired module length to form the array. Snap horizontal lines at the measured locations.
6. Mark and layout solar module vertical lines. Note: modules should not fall in shaded areas.

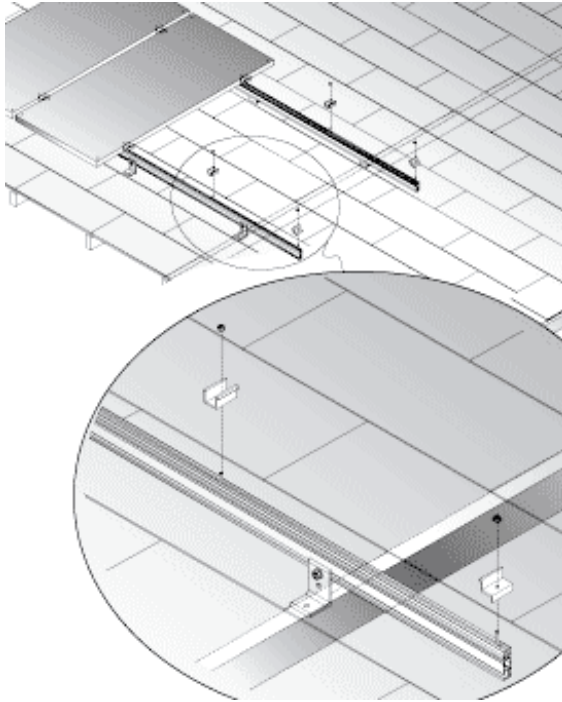

LAYING OUT L-FEET

L-foot (Fig. above) are used for installation through existing roofing material, such as asphalt shingles or sheet metal. In low-profile layouts, stagger feet on rafters (Fig. above) to distribute the load.

Installing L-feet

Drill pilot holes through the roof into the center of the rafter at each L-foot lag bolt hole location.

Lag bolts are not provided with Solar Mount rail sets.

Apply sealant into the hole, and on the shafts of the lag bolts. Seal the underside of the L-feet with a suitable weatherproof sealant.

Securely fasten the L-feet to the roof with the lag bolts. Ensure that the L-foot face as shown in Figure above. The single-slotted square side of the L-foot must always lie against the roof with the double-slotted side perpendicular to the roof.

INSTALLING RAILS

Keep rail slots free of roofing grit or other debris. Foreign matter will cause bolts to bind as they slide in the slots.

Installing Splices. If your installation uses solar splice bars, attach the rails together (Fig. below) before mounting the rails to the footings. Use splice bars only with flush installations.

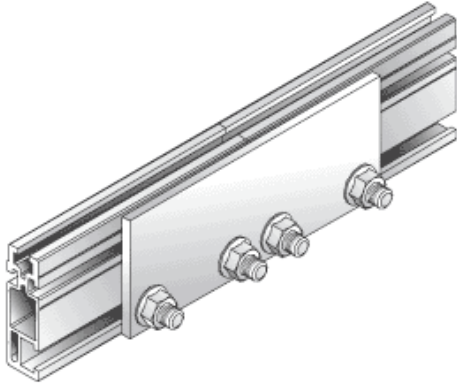

MOUNTING RAILS ON L-FEET

Rails may be attached to either of two mounting holes in the L-Feet (Fig. below). Mount in the lower hole for a low profile, more aesthetically pleasing installation. Mount in the upper hole for a higher profile, which will maximize airflow under the modules. This will cool them more and may enhance performance in hotter climates. Slide the 3/8-inch mounting bolts into the footing bolt slots. Loosely attach the rails to the footings with the flange nuts. Align one pair of rail ends to the edge of the installation area.



INSTALLING THE MODULES

If modules have standard J-boxes, each module should be pre-wired with one end of the inter-module cable for ease of installation. For safety reasons, module pre-wiring should not be performed on the roof. Leave covers off J-boxes. They will be installed when the modules are installed on the rails.

1.1 Installing the First Module.

In low-profile installations, the safety bolt and flange nut must be fastened to the module bolt slot at the aligned (lower) end of each rail. It will prevent the lower end clamps and clamping bolts from sliding out of the rail slot during installation.

If there is a return cable to the inverter, connect it to the first module. Close the J-box cover. Secure the first module with T-bolts and end clamps at the aligned end of each rail. Allow half an inch between the rail ends and the end

clamps. Finger tight the flange nuts, center and align the module as needed, and then securely tighten the flange nuts

1.2 Installing the Other Modules.

Lay the second module face down (glass to glass) on the first module. Connect inter-module cable to the second module and close the J-box cover. Turn the second module face up. With T-bolts, mid clamps, and flange nuts, secure the adjacent sides of the first and second modules. Align the second module and securely tighten the flange nuts.

For a neat installation, fasten cable clamps to rails with self-tapping screws. Repeat the procedure until all modules are installed. Attach the outside edge of the last module to the rail with end clamps.

Trim off any excess rail, being careful not to cut into the roof. Allow half an inch between the end clamp and the end of the rail. Check that all flange nuts on T-bolts are securely fastened.

5.2 SYSTEM GROUNDING

Upon completion of the array ground wire, bring to the rooftop junction box. Use at least a 10 AWG ground wire for this purpose. The ground will continue down to the DC disconnect and to the inverter. The inverter must be grounded to a ground rod. All of the Rails in an installation shall be provided with protective earth grounding wires when installed.

Accomplishing a code compliant grounding system is critical to the safety of the system. Continuous grounding of all modules and mounting system components is required.

1. Install outdoor rated ground lugs or ring terminals with ground wire. Use the marked ground hole on either end of the rail.
2. Connect a minimum # 10 AWG solid conductor, copper, ground wire to the ground lug or ring terminal.
3. Land the end of the ground wire in the array junction box.
4. Run the ground wire to the DC disconnect and inverter.
5. Run the ground wire from the inverter to a ground rod.

INSTALL INVERTER AS PER INVERTER INSTRUCTIONS